

NOTE:  
BREATHER MEMBRANE SHALL BE DESIGNED  
TO RESIST DIRECT WEATHER EXPOSURE  
AND U.V. AT JOINTS.

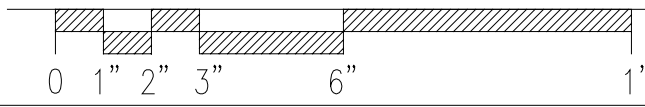
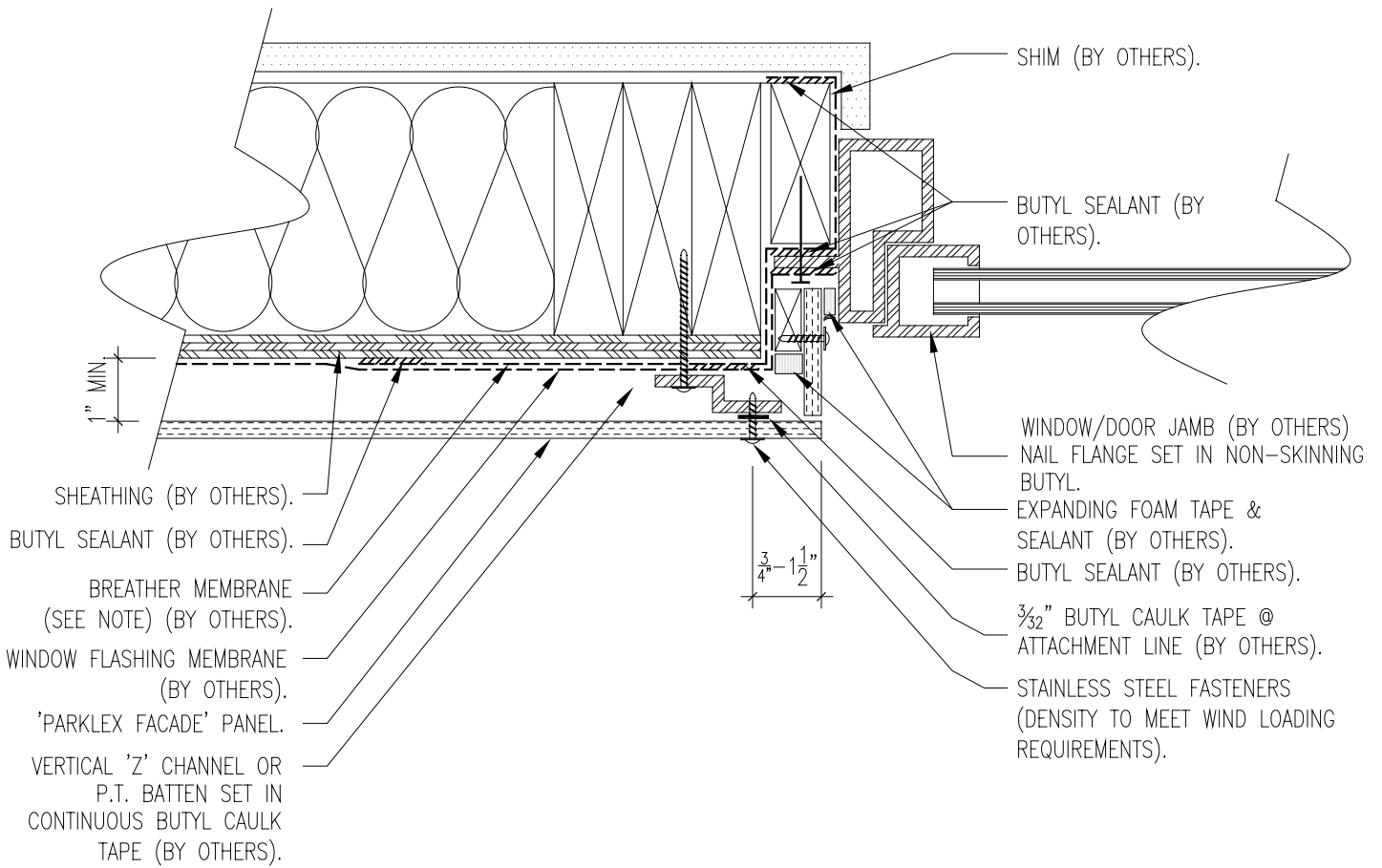

WINDOW DETAIL 7  
FLANGED WINDOW